

R20

Radius Windows

Radius Windows Milgard Aluminum Window

R-20
SERIES
ALUMINUM



The R-20 Series of Radius Windows are designed and engineered to provide a dramatic complement to architectural design either alone or combined with sliding, casement, or single hung windows. The window offers alternatives in glass for energy efficiency in 1" overall insulating units, plus frame and grid color options for virtually any architectural design.

Milgard's Aluminum windows, doors, and skylights carry a Full Lifetime Warranty to the original single family homeowner covering both materials and labor. The Milgard Full Lifetime Warranty is fully transferrable up to 10 years. For complete warranty details visit milgard.com

Commercial, apartment, multi-family, and co-housing projects are covered by a 10-year warranty from date of manufacture, covering materials and labor, including the glazing unit.

Radius Windows

Milgard Aluminum Window

CONFIGURATIONS

The R-20 Series features a frame designed to blend well architecturally with other Milgard windows. One extrusion is used for all radius and round windows. Attaching bars are used to join the radius tops with other variations. Please refer to the appropriate product description for examples of vents, weeping system, and other detailed information. The R-20 is attached to the 920 with a stacking bar by mechanical joining, pop riveting, or welded connections depending on the type of application. The minimum diameter for the R-20 Series is 2'6".

COMPONENTS

FRAME

Frame components are made from 6063-T5 aluminum alloy with a structural wall thickness of .060" and a non-structural wall thickness of .050". The R-20 Series utilizes a thermal break for added insulation value. The poured in polyurethane insulator is approximately 1/4" wide at the most narrow point and is used in all frame members. The frame is available in clear and bronze anodized finishes with a standard .4" mil coating thickness, and white baked enamel finish. The R-20 Series is designed for clean lines and high visual appeal with maximum glass exposure. Wide screw spacing on the mechanically joined corners ensure a rigid connection with a consistent dimension. Corners are sealed for added protection from the weather. The standard frame is 2 1/4" in width.

NAIL-ON FIN

An integral nailing fin extends 1" around the perimeter of the standard frame and is used to attach the window into the rough opening. The fin is scored for complete removal for retrofit/wood stop installations. The fin is setback 1 5/16" from the exterior edge of the frame.

GLAZING MATERIAL

AAMA approved glazing tape adheres the glass to the frame members glazing leg. The bedding seals and cushions the glass. Rigid vinyl setting blocks are used to support the unit above the frame sill, preventing glass slippage and glass-to-metal contact. Anodized or painted extruded aluminum bead 3/4" x 3/4", with a wall thickness of .050" is fastened down into the perimeter frame member on all radius sections.

GLASS

Glass options are available in 1" overall insulating units in clear, tinted, reflective, obscure, Low-E, and safety glass. Other specialty glass is available upon request. (See Glass Section for types and description.)

TOLERANCE

Due to unique material properties and manufacturing processes, tolerances on R-15 windows are +/- 1/4" on full round windows; partial rounds may vary +/- 1/8" in width and +/- 1/4" in height.

OPTIONS

GRIDS

Available in 5/8" standard or 1-1/16" sculptured aluminum profiles sealed between panes.

SPACER

Spacer available in a standard clear finish or optional bronze or champagne finish in the airspace of the insulating glass units. PGG Intercept™ warm-edge steel spacer available in certain regions. Contact your Milgard representative for spacers used in your area.

GLASS

Refer to Glass Section

COLORS

Check with local branch for color options and availability.

TEST STANDARDS

See Test Data Section

CAUTION: The use of petroleum based fuels or solvents as release agents in stucco wall installations or glass cleaning will chemically attack materials used in seals and other components, and voids the Milgard Full Lifetime Warranty. The use of wax based release agents is recommended.

Expanding foam for insulation purposes should not be used. Non-expanding foam or loose packed batt insulation is recommended.

R20 Aluminum Assembly Drawing

R-20
SERIES
ALUMINUM

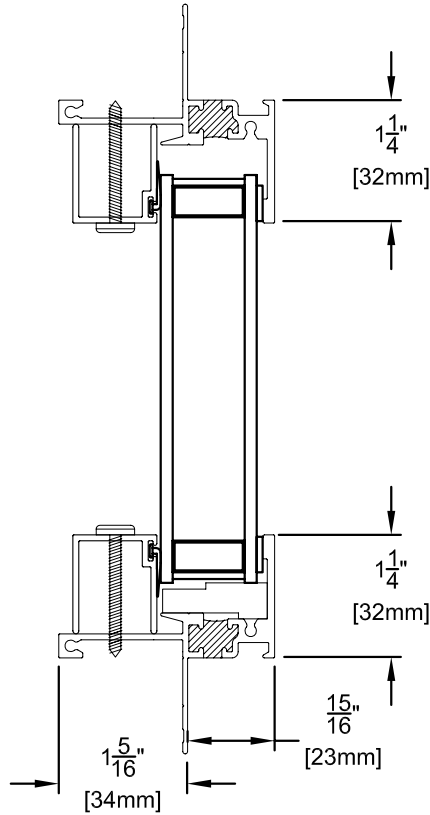

Vertical View

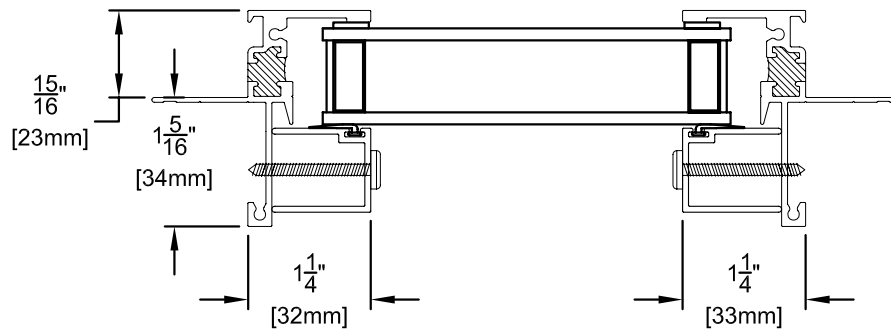

Horizontal View

Scale: 6" = 1' (1/2 scale)

Due to continual product research and development, details may be changed at any time. ©2009
Products shown are not available at all locations – confirm availability with your local Milgard representative.

R-20-4
APRIL 2009